

“Big Ben” Style Pen Kits With Twist-On Cap

Kit Features:

- Heavy 24kt gold-plating with epoxy coating.
- Pen designed to complement other "Big Ben" kits to create a set
- Heavy duty construction for people who like larger pens.
- Quarter-turn threaded front and back with an "O" ring to seal ink in nib.
- Fountain pen uses high quality German made iridium nib
- Roller ball pen kit contains gel ink refill
- The fountain pen nib and roller tip extensions are TN-coated for durability
- Overall length: 5-3/8" (closed)

- Fountain pen refillable ink cartridge is available #
- Disposable ink cartridge available #

Required Accessories:

- 7mm, long mandrel.
- 3 Pc. bushing Set #1121
- 10mm drill bit #1579
- 10mm barrel trimmer #1588.
- 2-part epoxy glue or cyanoacrylate glue.

Diagram A / Parts Layout

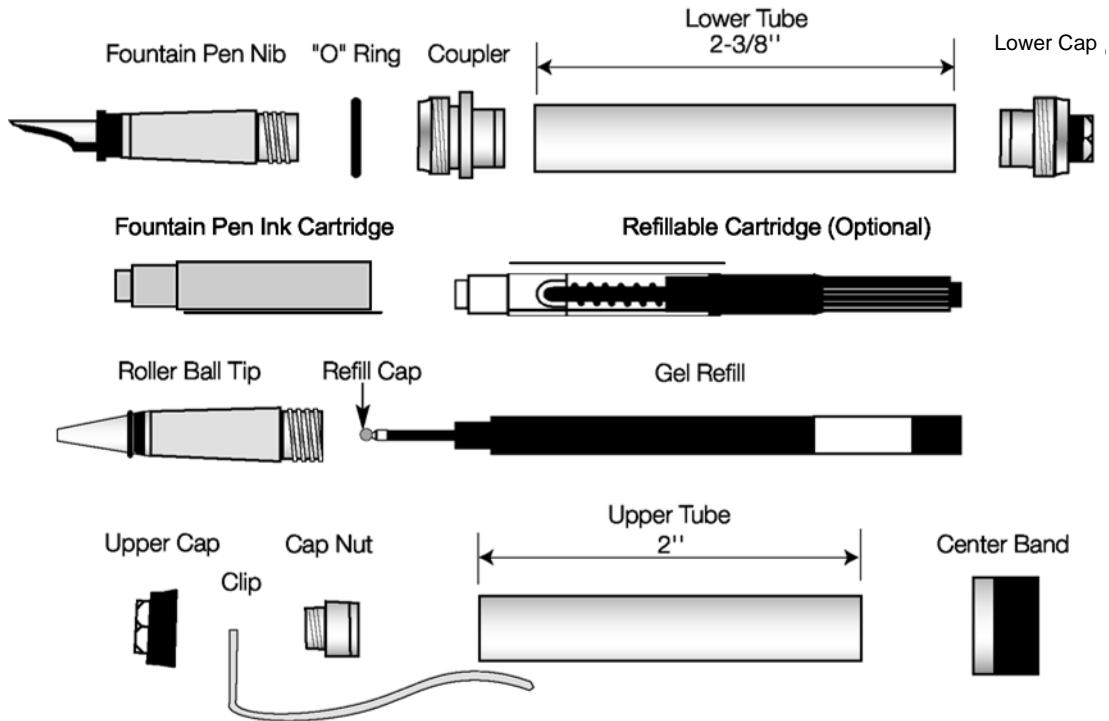

Preparing the Blanks

- Cut 7/8" to 3/4" square blanks to the length of the brass tubes (add 1/16" for squaring off).
- Drill a 10mm center hole lengthwise through each blank
- Spread glue over the tube. Insert into blank with a twisting motion to

spread the glue evenly inside. Center each tube lengthwise in the blanks.

- When glue dries, square ends of the blanks. Use a 10mm barrel trimmer to trim the wood down flush with the end of the brass tubes.

Diagram B / Turning The Blanks

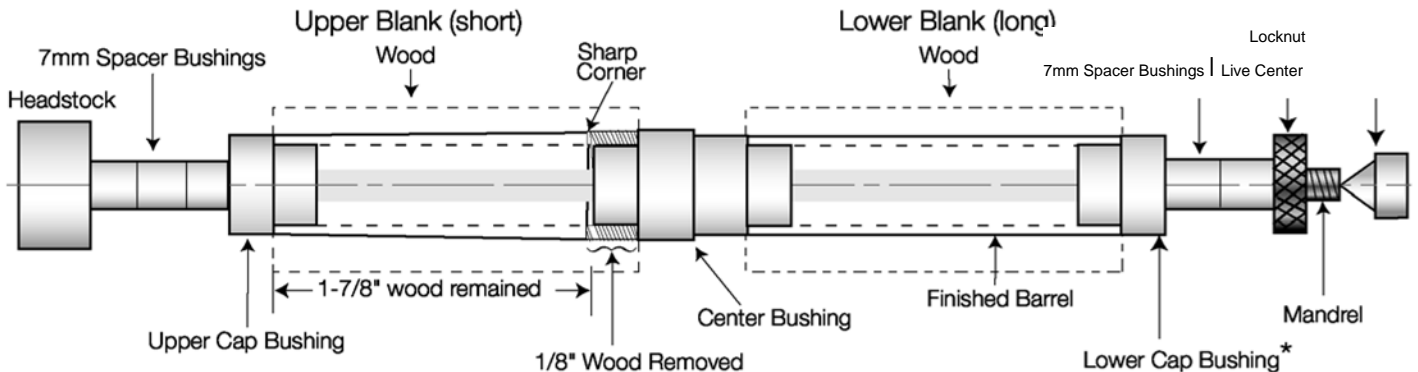

*see NOTE on other side.

Turning the Blanks

NOTE: When turning the wood down on the lower blank at the lower cap, do not take the wood down to the bushings. Leave a little extra wood. *The lower cap bushings diameter is slightly smaller than required.

- Place three or four 7mm spacer bushings on the mandrel shaft. Next, place the upper cap bushing (longer) wide end on first. Slide the (shorter) upper blank on next, follow with the center bushing, wide end in first. Place the (longer) lower blank on. Follow with the lower cap bushing (shorter). Fill in the space to the threads. Thread on the locknut. Bring the tailstock up to engage the live center with the

mandrel. Tighten the locknut. Lock the tailstock in place (do not over tighten, it could damage the mandrel).

- Turn the wood down flush with the bushings using lathe chisels and gradual lighter grits of abrasive.

Removing Wood For Center Band:

- Use a pencil to mark 1-7/8" from the upper cap bushing on the upper barrel. Use a parting tool to remove the excess wood down to the brass tube. Be careful, you must retain a 90° corner at the end of the upper blank when you remove the excess wood.
- Sand both blanks then finish the blanks with your choice of polish and waxes.

Assembly

Line up and identify finished parts according to Diagram A.

General:

- Press the coupler into the lower end of the lower barrel.
- Slip the "O" ring over the thread to rest in the groove.
- Press the lower cap into the opposite end of the barrel. the center band, gold end in first, over the recessed end of the (shorter) barrel (where the wood was removed).
- Press the cap nut, recessed end in first, into the opposite end of the barrel. Stop at the shoulder. Do not press in beyond the threads.
- Insert the clip hole over the threads of the upper cap and
- Drop the spring inside the lower barrel. Remove the gel refill cap. Insert flat end into the pen barrel. Screw the roller tip extension over the refill. The roller pen is now ready to use.

For the Fountain Pen

- Insert the ink cartridge narrow diameter end in first into the open end of the nib assembly. Press in to break the seal. Squeeze the cartridge lightly to advance the ink into the chamber of the nib. Place the assembly into the pen barrel snugly. The fountain pen is upper now ready to use.

Operating the Pen

- The pen is ready to operate. A quick quarter turn will screw the ends screw in tightly together. When using the pen, screw the cap over the body end. Always keep the tip covered when not in use to avoid the ink from drying up. **For the Roller Ball Pen**

Bushings (1121)

Upper Cap

Center

Lower Cap

Brought to you by:

The Wooden Post, Inc.

(888) 595-7126

www.woodenpost.com